

O-K Curb & Gutter Forms

BMF O-K curb, curb face, and gutter forms are made for all types of curb and gutter work, with or without division plates.

The curb form (back) is from the famous line of O-K curb forms, sufficiently rugged to provide rigid support for the curb face form.

All gutter forms have a 2 x 1 inch right angle flange at the top and a husky 2-1/2 inch flat flange at the bottom. The extended flat bottom flange provides

sufficient strength and will not trap spilled concrete. O-K gutter form design includes the rugged slide end lock and the O-K giant wedge stake pocket.

O-K forms are easily adaptable to any type of combined curb and gutter setting. The type of setting determines how the curb face form is supported. A mountable curb and gutter is set up in a similar manner except no face form is required.

On projects with division plates, the curb face form is securely locked to the division plates by the taper keys. Thus the curb face form may be entirely supported on two full division plates, or a combination of one full and one skeleton plate. Or, the curb face form may be entirely supported by a minimum of two skeleton (false division) plates spaced every five feet.

On projects where specifications require no breaks or scoring, complete suspension (without division plates) of the curb face form from the curb form (back) is accomplished by the use of two Adjustable Hanger accessories which hold the curb face form rigidly in place.

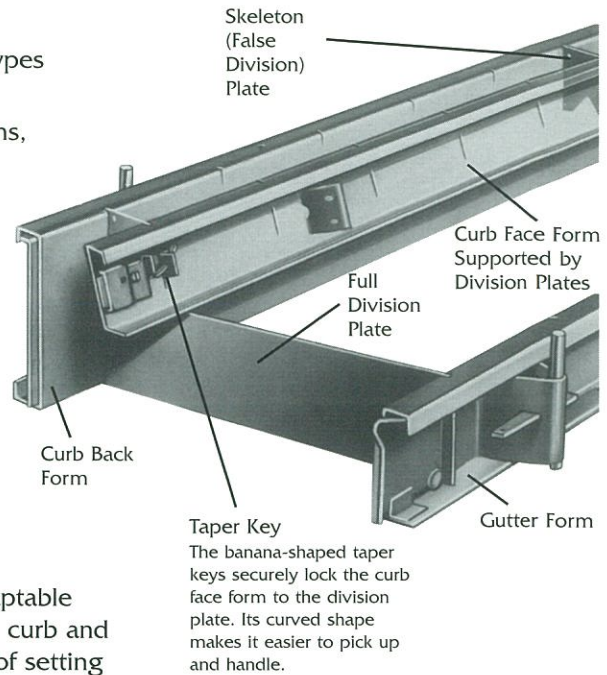

Specifications

Curb

Height, in.	12, 24
End Connection	Sleeve and Clamp
Division Plate Slots	10 per form (12 in. spacing)
Length, ft.	10 (three stake pockets)

Gutter

Height, in.	6" to 10
End Connection	Slide Cam Lock 3/16 in. thick
Division Plate Slots	10 per form (12 in. spacing)
Length, ft.	10 (three stake pockets)

*Same as O-K 6" straight sidewalk form.

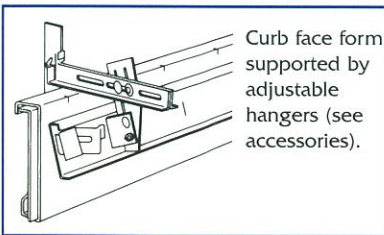

O-K Curb Face Forms

BMF manufactures a complete line of O-K Curb Face Forms for combined curb and gutter setting. Standard shapes that meet most specifications are illustrated below. However, any type and size can be supplied on order. See Guide to Ordering.

In combined curb and gutter form setting, the curb face form is the one that "takes the beating"; it is essentially a suspended member, depending on division plates or adjustable hangers for support. Therefore, the curb face form must be ruggedly constructed, and designed for rigid support. BMF engineers have taken these service factors into account.

O-K Curb Face Forms include the rugged and positive slide lock assuring ease of joining forms and rigid alignment once the slide lock is tapped into place. O-K Curb Face Forms are designed for the greatest adaptability in combination with other forms. When used with division plates, the curb face forms are quickly locked into and aligned with the tabs or ears in the division plates by simply tapping taper keys into place.

Standard Shape Face Form

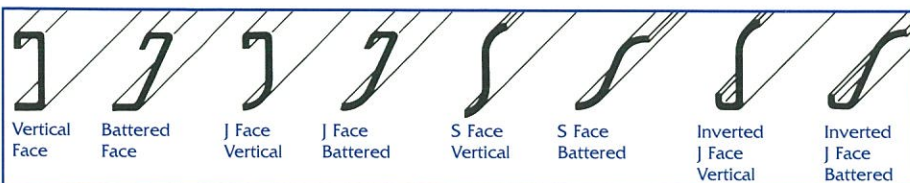

Specifications

O-K Curb Face Forms

Height, in.	6 to 9
End Connection	Slide lock, 3/16" Thick
Division Plate Slots	10 per form (12 in. spacing)
Length, ft.	10

Note: For stacking options please call Jaquith for technical data.

O-K Curb & Gutter Division Plates

Curb and Gutter	18 to 60
Width, in. (C)	
Curb Height, in. (B)	12 to 20
Curb Height (D)	See Guide to Ordering
Curb Face, Type and Height	Specify Standard Shape and See Guide to Ordering.

