

BILL OF MATERIALS				
ITEM	QUAN	DESCRIPTION	MAT'L.	DETAIL DWG.NO.
1	1	1 3/4" SQ. X 1/8" WALL PULTRUDED TUBE *	EXTREN 500	D-6155-28
2A	5	SOCKET 1 1/2 O.D X 5/16 WALL X 1 7/8 LG. TUBE	ALUM 6061-T6	D-6155-28
2B	5	SADDLE 1/8 X 2 X 5 1/16 ALUM. SHT.	ALUM 6061-0	D-6155-28
3	2	CRADLE 1/8 X 2 X 5 1/16 ALUM. SHT.	ALUM 6061-0	D-6155-28
4	2	WEATHER PROOF PLUG	RUBBER	D-6155-28
5	10	1/4-20 X 3/4 HEX SOCKET SET SCREW CUP PT.	SS	

* FIBER = T-30 FIBERGLASS ROVING WITH CONTINUOUS STRAND MAT OF 55% GLASS. POLYESTER SURFACE VEIL. BASE RESIN = ISOPHALIC RESIN.

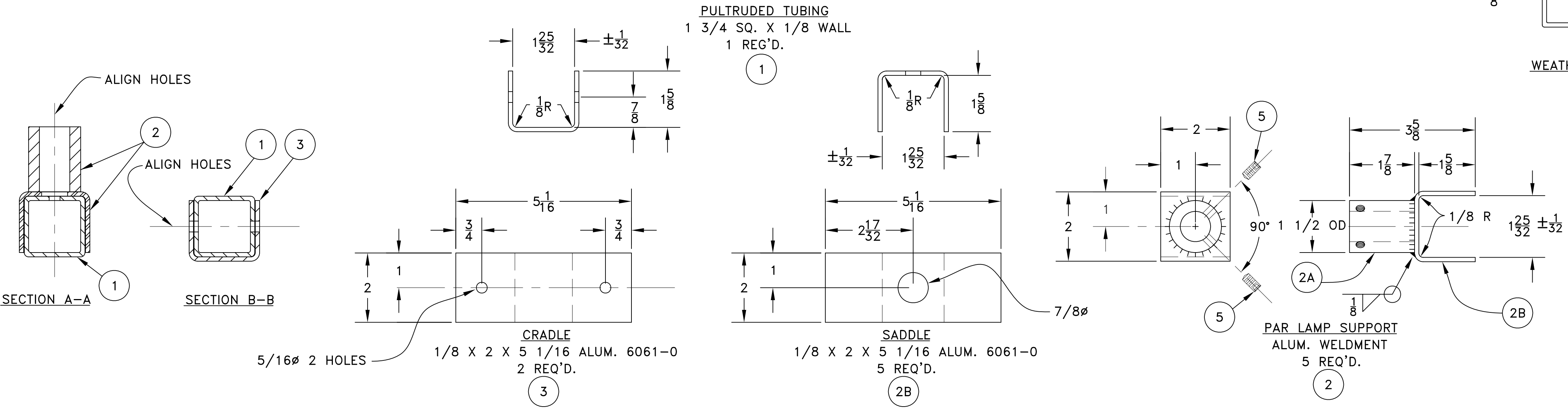
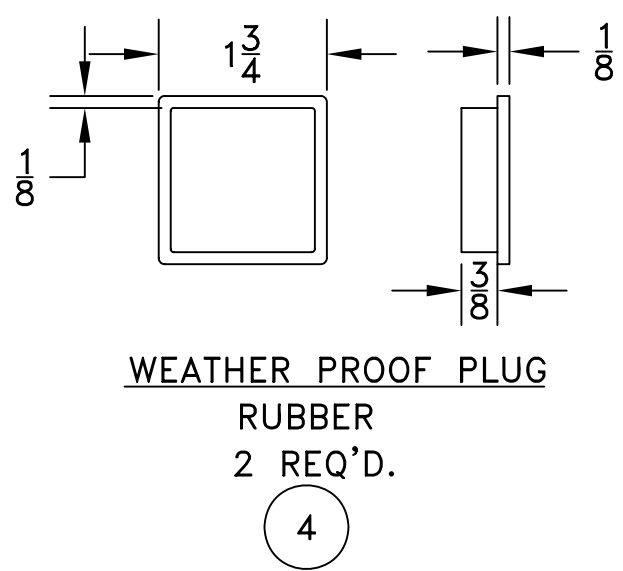
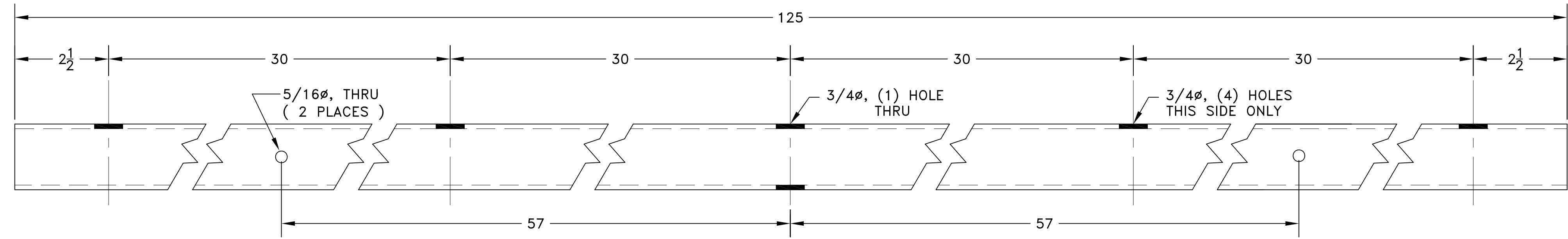

NOTE 'A': PULTRUDED TUBE SHALL HAVE ULTRA-VIOLET (UV) ABSORBER & ORANGE PIGMENT (COLOR 12197, FED. STD. 595) IN THE RESIN SYSTEM.

NOTE 'B': ALL HOLES AND CUT EDGES OF TUBE SHALL BE DONE IN FACTORY AND COATED WITH THE SAME AS THE ORIGINAL RESIN.

NOTE 'C': ALL SURFACES TO BE BONDED TOGETHER, SHALL BE ROUGHENED AND CLEANED WITH MEK OR ACETONE PRIOR TO BONDING.

NOTE 'D': TUBE SURFACES WILL BE LIGHTLY ROUGHENED AND WIPED DOWN WITH MEK OR ACETONE PRIOR TO APPLYING ONE WET COAT OF SHERWIN WILLIAM'S HIGH SOLIDS POLANE OR EQUAL, TO ATTAIN 1 1/2-2 MIL. DRY FILM THICKNESS. COLOR SHALL BE 12197 PER FED. STD. 595.

NOTE 'E': FOR 1 3/4 SQ. PULTRUDED TUBES, ALLOWABLE TOLERANCE DEVIATION OF DEPTH AT CORNERS FROM 1 3/4 = ±0.02" DEVIATION FROM STRAIGHT = 0.02"/FT. LENGTH. TWIST FROM LONGITUDINAL AXIS - 1/2"/FT. LENGTH.

NOTE 'F': ALL ALUMINUM SHALL BE ANODIZED WITH A MATT FINISH PER MIL-8625, TYPE 2, CLASS 1.

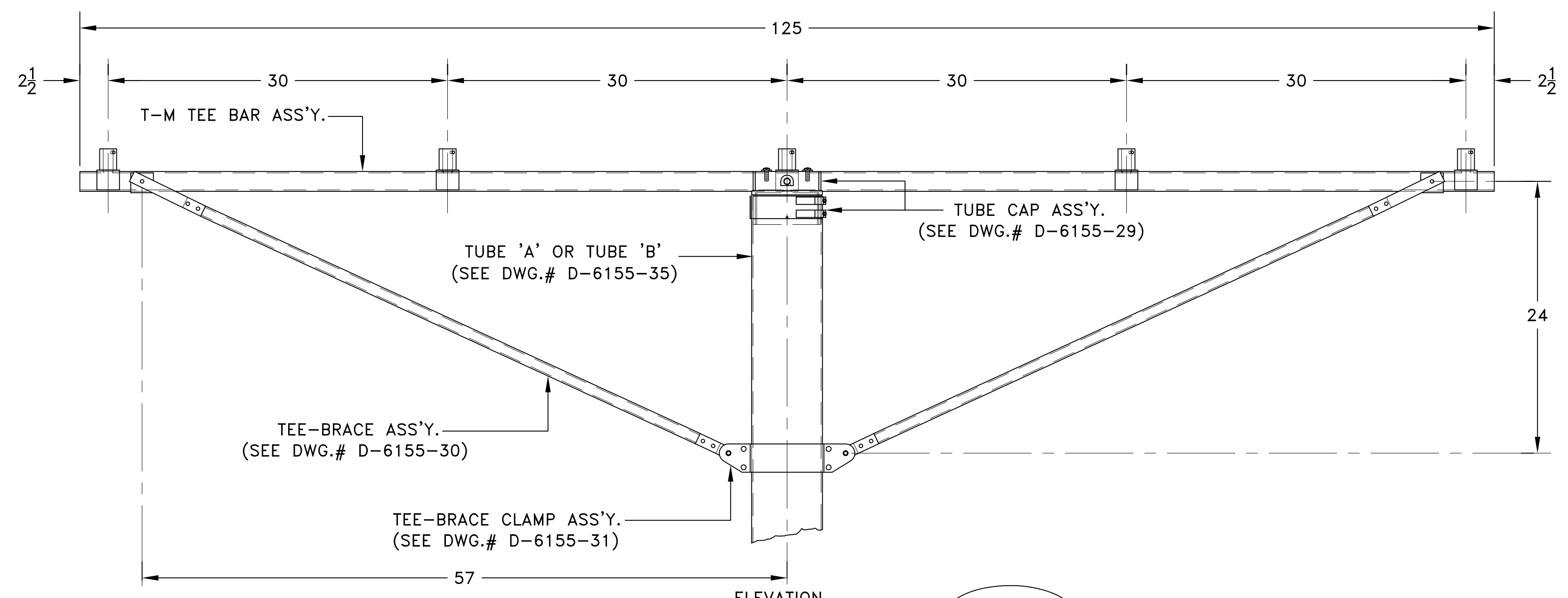
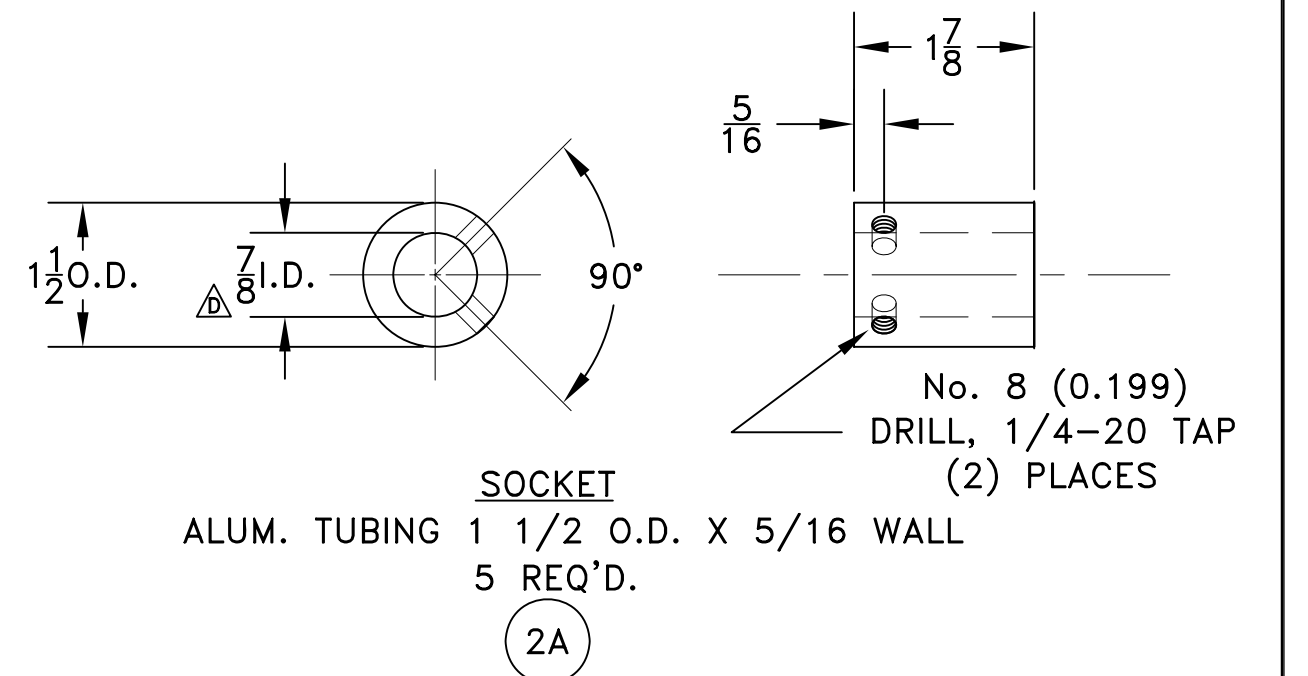

FACTORY ASSEMBLY NOTE :
 FACTORY TO BOND (5) LAMP SUPPORTS (2) AND (2) CRADLES (3) TO (1) TEE BAR (1).
 USE EQUAL PARTS OF FUSOR 304-1 & 2 (JAQUITH No. L-7012)

REV.	LTR.	DATE	DESCRIPTION	CHECKED	APPROVED
E		10-30-6	MINOR REVISIONS	mJm	
D		04/20/04	GENERAL CORRECTIONS TO DRAWING	R.D.P.	
C		07/03/00	REDRAWN TO ACAD 2000 FORMAT	REX	
B		10/27/86	6061-0 ALUM. WAS 6061-T6	R.D.P.	
A		4/3/80	NOTE 'D' & 'C' - CHANGE PAINT & CLEANING ISTR.	R.D.P.	JA

DEPARTMENT OF TRANSPORTATION
 FEDERAL AVIATION ADMINISTRATION
 WASHINGTON, D.C. 20591

ALSF-2 (6' - 128') & MALSR (6' - 128')
 L.I.R. STRUCTURES
 LIGHT MOUNTING HEIGHT 6'-1" TO 128'-0"
 T-M TEE BAR ASSEMBLY

REVIEWED BY	SUBMITTED BY	APPROVED BY
DESIGNED BY	ISSUED BY	TECHNICAL OFFICER
DRAWN BY	DATE	REV. LTR.
CHECKED BY	DRAWING NO.	
	D-6155-28	E

JAQUITH INDUSTRIES INC.
 PO BOX 780
 600 E. BRIGHTON AVE.
 SYRACUSE, NEW YORK 13205
 www.jaquith.com 315-478-5700

ALL THE DIMENSIONS IN INCHES UNLESS OTHERWISE SPECIFIED

1
 D-6155-24